



Leibstadt
Nuclear Power Plant

Technical Description

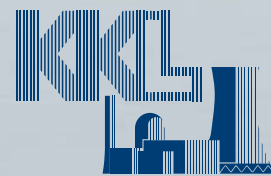



Photo: Ruth Schmidt

Leibstadt Nuclear Power Plant generates power for more than a million people every day.

Table of Contents

Leibstadt Nuclear Power Plant – an important partner	4
Our nuclear plant – your power	5
From construction to the present day	6
Leibstadt Nuclear Power Plant at a glance	7
How the power plant works	8
Nuclear installations	9
■ Nuclear steam supply system	9
■ Reactor control	10
■ Fast shutdown	11
■ Fuel assemblies	12
■ Auxiliary facilities	14
Cross-section view of the plant	16/17
Conventional installations	18
■ Main heat cycle	18
■ Turbine-generator set	19
■ Generator	20
Cooling systems	22
■ Main cooling system	22
■ Auxiliary cooling system	23
■ Emergency cooling system	23
Electrical installations	24
■ Main transformer	24
■ House load	24
■ Emergency power supply	25
■ Remote Shut-Down Areas	25
The fuel used at Leibstadt Nuclear Power Plant	26
■ Fuel procurement	26
■ Fuel consumption	26
■ Reprocessing	26
Waste	27
■ High-level radioactive waste	27
■ Low and medium-level radioactive waste	27
■ Transportation and storage containers	27
Safety of the Leibstadt Nuclear Power Plant	28
■ Protection of people, the environment and the plant	28
■ A permanently practiced culture of safety	29
■ Regulatory control	29
Environmental aspects	30
■ Greenhouse gases	30
■ Emissions into the air and water	30

Imprint

First edition April 2011

Kernkraftwerk Leibstadt AG, 5325 Leibstadt, Switzerland

Overall direction: Barbara Bumbacher,
Leibstadt Nuclear Power Plant

Concept and editing: Ruth Schmid,
Leibstadt Nuclear Power Plant

Technical advice: Ulrich Schläppi,
Leibstadt Nuclear Power Plant

Layout: Markus Etterich, Basel

Graphics: Edith Huwiler, Zurich

Photos: Palma Fiacco, Zurich; Karin Gfeller, Leibstadt Nuclear Power Plant; Peter Graf, Leibstadt Nuclear Power Plant; Daniel Schläfli, Kleindöttingen; Ruth Schmid, Leibstadt Nuclear Power Plant; Ivo Stalder, Leibstadt Nuclear Power Plant

Print: Offsetdruck Kramer, Leibstadt



Leibstadt Nuclear Power Plant – an important partner

With a capacity of 1245 MW, Leibstadt Nuclear Power Plant is situated on the Swiss side of the Upper Rhine, between Koblenz and Laufenburg and close to the confluence of the Rhine and Aar rivers. It was commissioned on 15 December 1984 as Switzerland's fifth nuclear power station. After Beznau I, Beznau II, Mühleberg and Gösgen, Leibstadt is the country's newest and most powerful nuclear power plant. Since 1984, it has reliably produced approximately one sixth of Switzerland's electricity needs. This corresponds to roughly 29 million kilowatt-hours per day.

Leibstadt Nuclear Power Plant is a joint stock corporation. In total, seven electricity companies have different levels of shareholdings in Kernkraftwerk Leibstadt AG (KKL): AEW Energie AG, Alpiq AG, Alpiq Suisse SA, Axpo AG, BKW-FMB Beteiligungen AG, Centralschweizerische Kraftwerke AG (CKW) and Elektrizitätsgesellschaft Laufenburg AG (EGL). With a total of 52.7 percent, Axpo Holding AG holds the majority of the shares. Leibstadt Nuclear Power Plant is managed by Axpo AG.

The power plant employs about 500 Swiss and foreign staff, the latter living near the Swiss border. More than 20 percent of the plant's employees come from Germany. Leibstadt Nuclear Power Plant is an attractive provider of secure long-term employment and training opportunities in the wider region. Beyond this, the company is an important partner for numerous suppliers and service providers and is thus of considerable economic importance.

Safe, reliable and cost-effective, this is the way Leibstadt Nuclear Power Plant would like to continue to produce electricity in the future, on behalf of and according to its owners, at least until the year 2045. In doing so, protecting people and the environment from radioactive and conventional hazards will remain the plant's top priority in the years to come.

Leibstadt Nuclear Power Plant generates power for more than a million people every day.

Our nuclear power plant – your power

Power for one million people

Hydroelectricity and nuclear power are the pillars of Swiss electricity production. About 40 percent of Switzerland's basic supply of power is generated by the five Swiss nuclear power stations. Leibstadt Nuclear Power Plant (KKL) makes a considerable contribution to ensuring an interruption-free energy supply for Swiss electricity consumers. Since 1984, it has produced more than nine billion megawatt-hours per year, i.e. over 15 percent of Switzerland's electricity requirements – a reliable service which is provided around the clock.

Safety first

Multiple-redundant safety systems, a highly developed safety culture, and the technical and social competence of employees all guarantee that Leibstadt Nuclear Power Plant is operated with Swiss reliability. Thanks to the continuous improvements in all areas, it matches the safety standards of the best power plants anywhere in the world. Procedures involving the interactions of people and equipment are regularly revised and processes optimized. If certain operating limits are exceeded, the reactor is automatically shut down.

In cooperation with the federal government and the authorities, KKL ensures that all applicable legal requirements for the protection of people and the environment are fulfilled at all times. Safety invariably takes priority over profitability.

Economic importance

Leibstadt Nuclear Power Plant is a power factory. The electricity generated is made available at cost to shareholders, mostly publicly owned companies. Cantons and municipalities, electric power companies, and private end consumers all benefit from the attractive production costs of power generated in Leibstadt. For years, the price has been around five Swiss centimes per kilowatt hour – a very low rate by international standards. This figure includes the costs of decommissioning the plant as well as waste disposal (1 centime/kWh). With five to ten percent, fuel accounts for a relatively low proportion of the production costs, meaning that the plant can guarantee low and stable electricity prices in the long term. From SMEs to large industrial enterprises, everyone benefits from these low and stable prices. KKL thereby

Photo: Ruth Schmid



Pure water vapor comes out of the cooling tower.

helps the country to maintain its international competitiveness despite high infrastructure and labor costs.

For the sake of the climate

What comes out of the KKL cooling tower is pure water vapor. The power plant itself neither emits CO₂ nor other greenhouse gases or air pollutants. This is not the only reason why KKL is an environmentally- and climate-friendly plant. Even all upstream and downstream processes, from the uranium mine to deep geological repositories, produce very low emissions.

A form of independence

The domestic nuclear and hydroelectric power plants ensure that Swiss electrical power maintains a high degree of independence from other countries. Uranium, the fuel used in nuclear energy generation, is mined in many countries around the globe and has a very high energy density. This means that only relatively low quantities need to be imported and that they can be easily stored. Consequently, KKL can draw up reliable long-term power supply plans.

On a solid footing

When the nuclear power plant was built, it was contractually agreed that KKL AG would supply Leibstadt Municipality with part of its annual electricity requirements. However, since the nuclear power plant is not a utility, KKL AG compensates Leibstadt Municipality for the equivalent of roughly one third of its yearly power consumption. In addition, KKL AG pays yearly contributions to the "Pro Leibstadt Foundation" to promote cultural and charitable projects in the Leibstadt Municipality. Through the information center – a venue for meeting and exchanging ideas – Leibstadt Nuclear Power Plant makes a significant contribution to the social life in the region.

From construction to the present day

Kernkraftwerk Leibstadt AG (KKL) was founded on 26 November 1973, and a partner agreement was originally signed with 14 companies. When the plant began commercial operation at the end of 1984, the company already had a history of planning and construction going back roughly 20 years. Before the planning of Leibstadt Nuclear Power Plant began, site investigations had confirmed the suitability of the site for a nuclear plant, particularly with regard to the geology, transmission of electrical power, accessibility for heavy transport vehicles and other factors. The location on the Rhine was especially important, since it provides a sufficient water supply for the cooling circuit at all times. Its low seismic activity was also an argument in favor of Leibstadt as a suitable location. In the northern part of the Swiss plateau such activity is much lower than, for example, in the narrower Alpine region. This is important with regard to the safety of the plant, even if, as is the case with Leibstadt Nuclear Power Plant, it is designed to withstand very strong earthquakes. Allowance was also made for high environmental protection requirements. Since the federal government prohibited cooling with river water during the 1971 project phase, plans for the plant's cooling system had to be redesigned to incorporate a cooling tower.

Numerous project planning delays made it possible to increase the originally intended output of 600 MW to 960 MW and to upgrade the plant to reflect the latest technological improvements. The total construction costs amounted to roughly 4.8 billion francs – a costly investment, but also one which is safe and attractive in the long run and is paid off during the scheduled service life of 60 years.



Photo: Archiv KKL

Construction of Leibstadt Nuclear Power Plant took about ten years

From 1998 to 2003, operations were incrementally optimized. The net output of the power station rose to 1165 MW. In the course of continuous innovations and modernizations, major components such as low-pressure turbines and the unit transformer were replaced. Thanks to systematic efficiency improvements, the net output had increased to 1245 MW by 2010. The safety of all these improvements was demonstrated in great detail to the competent regulatory authority, i.e. the Swiss Federal Nuclear Safety Inspectorate (ENSI).

Since the start of operations, Leibstadt Nuclear Power Plant has invested almost 700 million francs in safety and efficiency, meaning that the station continues to incorporate the latest technological innovations.



Photo: Palma Fiacco

Thanks to constant maintenance and upgrades, Leibstadt remains a state-of-the-art nuclear power plant.

Leibstadt Nuclear Power Plant at a glance

Leibstadt Nuclear Power Plant is situated on the south bank of the Rhine river in Leibstadt, northern Switzerland, close to the confluence of the Rhine and Aar rivers near Koblenz (Switzerland) and Waldshut (Germany). Today, the entire power station site, including car parks, covers 24 hectares of land. Although the plant generates a considerable 15 percent of Switzerland's power requirements, the plant's land use is modest compared to other power generating systems.

The power plant itself is concentrated on a supervised and fenced area of twelve hectares. The most important buildings are marked in red: the fuel assembly storage building, the reactor building and the turbine building. To their west are the auxiliary buildings such

as the office building, workshop and warehouse, service and the treatment building in which radioactive waste is processed and put into barrels.

East of the main buildings are mainly additional warehouses, the main water cooling system with the pump house and the cooling tower. To ensure that these power station buildings are not overly dominant features of the landscape, their foundations were built 8 meters below ground level and the 144 meter tall cooling tower 15 meters below ground level. Central parts of the plant are extremely solidly built, with some parts constructed underground. As a result, they offer maximum safety for the plant and the environment.

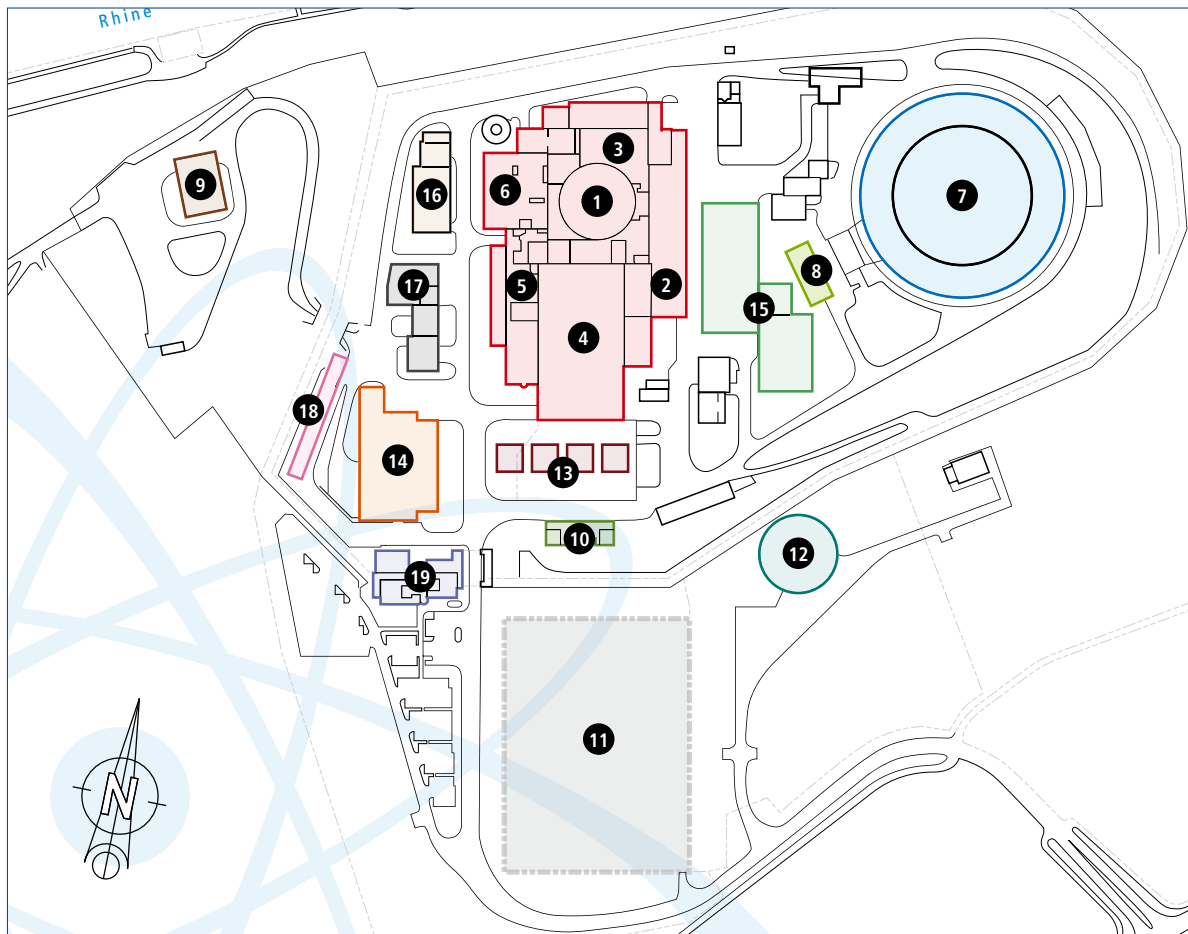

- | | | |
|----------------------------------|------------------------------------|----------------------------|
| 1 Reactor building | 8 Main cooling water pump house | 15 Warehouse |
| 2 Workshop | 9 Auxiliary cooling water system | 16 Barrel storage |
| 3 Fuel assembly storage building | 10 50-kV switchyard | 17 Mock-up building |
| 4 Turbine building | 11 380-kV switchyard | 18 Infrastructure building |
| 5 Service building | 12 Information and training center | 19 Office building |
| 6 Treatment building | 13 Unit Transformer | |
| 7 Cooling tower | 14 Workshops, storage | |

Layout of the power plant.

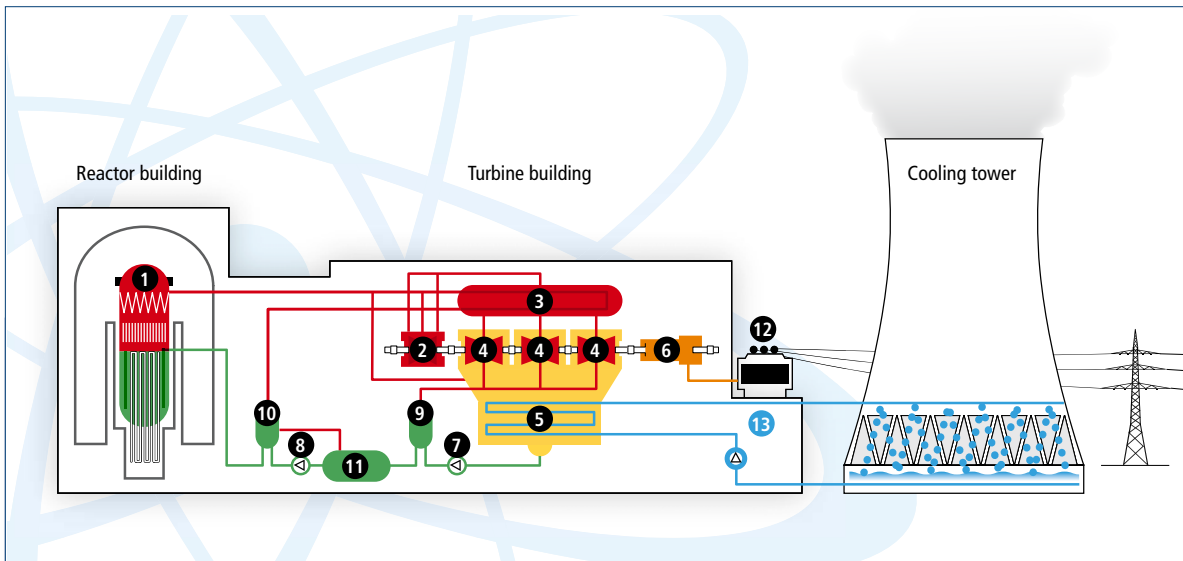

- 1 Reactor
- 2 High-pressure turbine
- 3 Water separator/
intermediate superheater
- 4 Low-pressure turbine
- 5 Condenser
- 6 Generator
- 7 Condensate pump
- 8 Feed water pump
- 9 Low-pressure preheater
- 10 High-pressure preheater
- 11 Surge tank
- 12 Main Transformer
- 13 Main cooling water
- ⊙ Pumps

In a boiling water reactor, the generated steam is directly used to drive the turbines and then converted into water in the condenser. The water is then transported back to the reactor by pumps. This is the primary closed-loop water / steam cycle. This is completely separate from the cooling system of the condenser via the cooling tower.

How the power plant works

The Leibstadt Nuclear Power Plant uses light water reactor technology, which has a proven track record going back several decades. Most of the roughly 440 nuclear power plants in operation worldwide are based on this fundamental technology, which has given rise to two main types: Pressurized Water Reactors and Boiling Water Reactors. "Light water" here refers to normal water (H₂O) used in the reactor for cooling and moderation purposes, as opposed to "heavy water" (D₂O) which is only used in a few other reactor types. Leibstadt uses a Boiling Water Reactor.

Energy is released as part of the fission of uranium atom nuclei in the reactor. As a result, the water in the reactor is heated and steam is formed which is fed, via four steam lines, into the high-pressure turbine and then into the three low-pressure turbines. The steam drives the turbines which in turn drive the generator via a fixed coupling. Thermal energy is thereby converted into mechanical energy and the generator then turns this me-

chanical energy into electric energy which is fed into the high-voltage network via the unit transformer. Once the steam has gone through the turbines, it is cooled down in the condenser. It subsequently condenses back into water which is transported back to the reactor by pumps. This primary water circuit is completely separate from other circuits. The turbine condenser is cooled with water from the cooling tower.

The nuclear power plant is monitored and controlled from the control room. From this room, operators trained over many years supervise the system around the clock. They "drive" the reactor, turbines and generator and regularly check the functions of all plant components and systems. The operators are examined by ENSI and are required to renew their license every two years. In preparation for the exams, the operators must spend a prescribed number of hours training under normal operation as well as emergency scenarios using the plant's own simulator.

Nuclear installations

■ Steam generating system

The reactor is the heart of every nuclear power plant. In Leibstadt, it is a BWR/6 Boiling Water Reactor from General Electric, the American nuclear power vendor. This boiling water reactor is used to generate steam for the system. A typical feature of this type of construction are the external circulation pumps. Compared to the overall plant, the dimensions of the reactor are relatively small. The pressure vessel surrounding the reactor core measures 6 m in diameter and 22 m in height. It consists of a 15 cm thick steel wall confining the fuel assemblies, water separator, steam dryer, and control rods.

The reactor core consists of 648 fuel assemblies, each containing 96 fuel rods in a 10 x 10 arrangement. The fuel rods are filled with enriched uranium dioxide pellets. The reactor is licensed for a normal thermal power of 3600 MW with an average power density of 62.7 kW/dm³.

During operation, the water in the reactor pressure vessel is at a pressure of 73.1 bar, raising the boiling point of the water to 286 °C. When the water flows through the hot reactor core it absorbs heat and leaves as a mixture of steam and water. The moisture separator removes water from the steam. The recirculation system returns the separated water back to the reactor core by

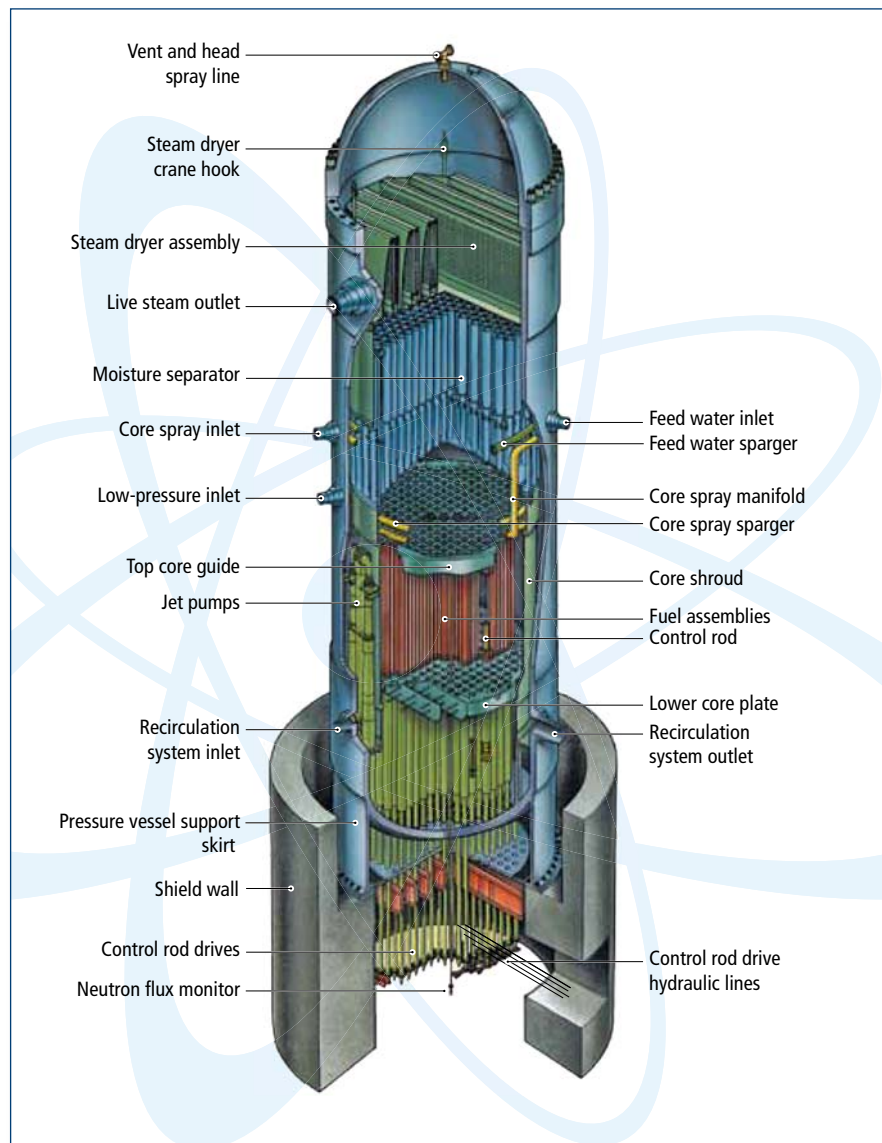



Photo: Daniel Schläfli

During maintenance work, the inflatable crocodile makes the surface of the crystal clear reactor water clearly visible – a simple yet effective safety precaution.

pumping it through the space between the pressure vessel and reactor core. Steam leaving the moisture separator is dried in the steam dryer and then travels to the turbines via the main steam lines. This steam is slightly radioactive. For this reason, the turbine area is not accessible during operation. However, following shutdown of the reactor radiation decreases to safe levels within a few minutes.

Nuclear fission as the heat source

Energy is created by splitting atom nuclei in the reactor core (nuclear fission). A neutron hitting a fissionable uranium 235 nucleus breaks the nucleus into two or more smaller nuclei resulting in the release of heat and radioactivity. When this happens, two or three neutrons are also released which can cause more nuclear fission. If a new fission follows each predecessor it is called a self-sustaining chain reaction. At the same time, the water in the reactor functions as a moderator: it is responsible for slowing down the fast neutrons produced by fission from 20,000 km/s (in 2 s around the world) to 3 km/s. Only slow (thermal) neutrons can cause further nuclear fission.

■ Reactor control

The Reactor power output is controlled by changing the amount of water being circulated through the core and by the insertion and withdrawal of the 149 control rods. They are hydraulically inserted into the reactor core from below and can be moved individually or in groups by a Rod Sequence Program. Boron carbide in the control rods absorbs thermal neutrons. The further the control rods are inserted into the reactor core, the more neutrons will be absorbed and the fewer nuclear fissions will take place, i.e. power is reduced. Similarly, the further the control rods are withdrawn from the reactor core, the more neutrons will be available for fission, thereby increasing the power.

Driven by two external circulation pumps, twenty jet pumps circulate the water inside the reactor core. Up to 11 m³ of water is thus circulated per second. By increasing the circulation rate, fewer steam bubbles are created which can be removed faster from the reactor core, thereby increasing moderation and power output. Conversely, power output drops when more steam bubbles are produced due to a reduction in the rate of water circulation. Since steam does not slow down neutrons, no moderation can take place inside the bubbles.

A three-channel electronic pressure regulator ensures constant reactor pressure by controlling the turbine inlet valves. The bypass system controls the reactor pressure when the reactor produces more steam than the turbine can accept. This is the case when the turbine is being started or shut down. The system throttles the main steam to the turbine and redirects it into the condenser.

To prevent stress corrosion cracking in the reactor pressure vessel, hydrogen together with platinum has been fed into the reactor water since 2008. Comparable to a vaccination, this helps extend the service life of the reactor pressure vessel. As a result of this measure, the entire plant can safely remain in operation for at least 60 years.

Designed for 70% of the normal live steam flow, this bypass can temporarily accept 110%. This means that, if required, pressure can be diverted from the turbine instantly and without the need for a quick shutdown of the reactor (for example, in case of a power failure). Since the reactor remains in operation, the system can be quickly reconnected to the electric grid.

■ Fast shutdown

An automatic reactor shutdown system protects the plant from excessive loads. This reduces the consequences of a malfunction to a safe level and helps prevent damage to components such as the fuel cladding tubes. Numerous instruments are used to monitor the plant: if maximum permissible values are reached, the system starts the fully automated fast shutdown of the reactor (Scram). In this process the control rods are fully inserted into the reactor core within two seconds, which immediately stops fission. For this purpose, each rod drive has a nitrogen pressure reservoir as an energy reserve. After the scram, the turbines are turned off and the generator is taken off the electric grid. The reactor is further cooled down and the decay heat generated by the fission products in the fuel rods is dissipated. The reactor is thus in a safe condition.

The reactor protection system has its own separate power supply, transducers and the trigger mechanism for fast insertion of the control rods. Four independent trigger channels ensure that the reactor can always be shut down safely, even in case of a power failure. Alternatively, a scram can be triggered manually.

A look into the open reactor clearly shows the shiny new fuel assemblies.

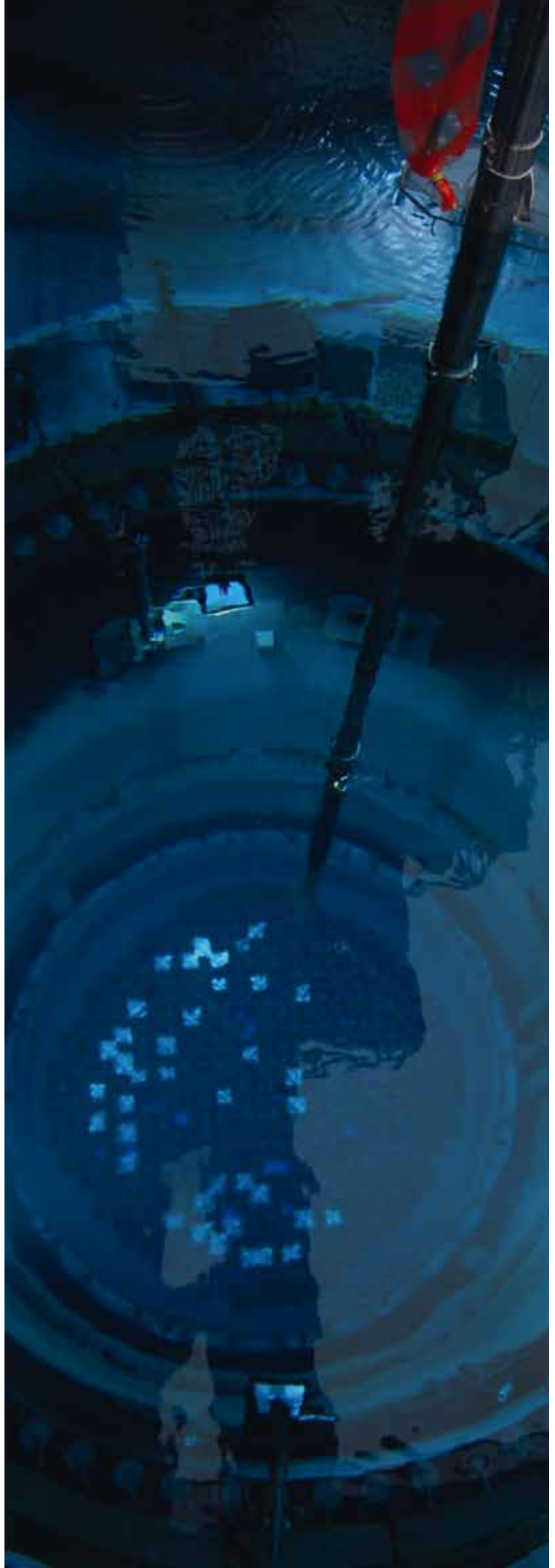



Photo: Palma Fiacco

A special crane lifts off the lid of the reactor pressure vessel during the main annual outage.

Fuel assemblies

The fuel used in the reactor is uranium in the form of uranium dioxide (UO_2). It is pressed and sintered into fuel pellets and then put into long thin cladding tubes made of Zircaloy. This zirconium alloy is inherently very stable even at high temperatures and enables high neutron flow. Roughly one hundred such fuel rods form one fuel assembly. The entire reactor core in turn contains 648 fuel assemblies. Each one of them is approximately 4.5 m long and weighs 300 kg.

New fuel assemblies are delivered from the manufacturing plant to Leibstadt Nuclear Power Plant using conventional transport boxes.

Since the fuel assemblies are not radioactive until they are used in the reactor, no special radiation protection measures are required. Once they have reached Leibstadt Nuclear Power Plant, the fuel assemblies are checked for transport damage.

Fuel reloading is carried out every year during the summer months, when electric power demand is at its lowest. For this purpose, the reactor is shut down. As part of the annual major outage, which takes three to

five weeks to complete, about one fifth of the total 648 fuel assemblies are replaced by new ones.

The remaining fuel assemblies are relocated to ensure that they are optimally and evenly utilized. At the same time, a multitude of repairs, inspections and modifications are carried out throughout the entire plant.

The head of the reactor pressure vessel has to be removed before the fuel assemblies can be replaced. The steam dryer and moisture separator assembly are dismantled and stored under water. Using a telescopic mast, the spent assemblies are withdrawn from the reactor and transferred, always underwater, to the spent fuel storage pool where they remain for several years. Once their radiation and decay heat have sufficiently decreased, they are transported in special shielded containers to the interim storage facility in nearby Würenlingen. They were also sent to reprocessing plants until the ten-year moratorium came into force in mid-2006.

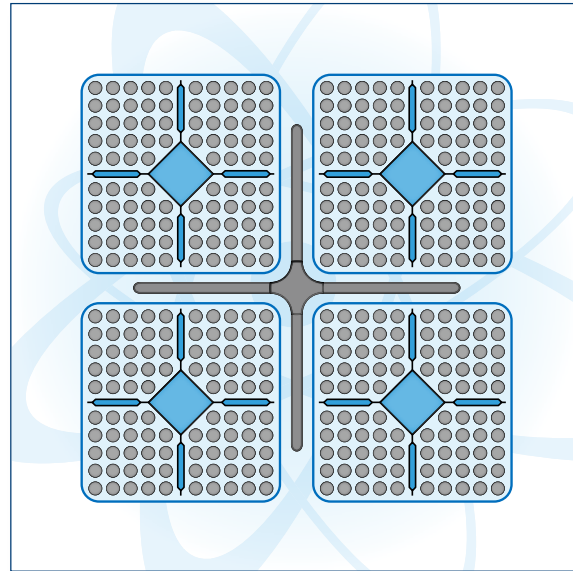

Each control rod unites four fuel assemblies. The cross section shows the diamond-shaped water channels in the fuel assembly. Water also flows between the fuel rods and all fuel assemblies in the reactor core.



A robotic arm is used to move the fuel assemblies in the spent fuel storage pool.

Photo: Daniel Schläfli



■ Auxiliary facilities

Various auxiliary facilities support the safe operation of the nuclear part of the plant. The reactor auxiliary building contains all the auxiliary equipment needed to maintain core cooling during reactor shutdown. Three independent remote shutdown rooms are also located in this building.

The fuel storage building houses the cooling pool in which spent fuel assemblies are stored under water. A special system provides water treatment and cooling. Spent control rods are stored in the same pool. After the decay time, they are disassembled into smaller parts under water, put into containers fit for final disposal and, like the fuel assemblies, transported to the interim storage facility in Würenlingen.

A special transport system for fuel assemblies connects the Spent Fuel Pool and the containment pool. By means of this transfer tube, fuel assemblies are transported down from the reactor core to the Spent Fuel Pool and new fuel assemblies up to the reactor.

The Radwaste building houses the system for treating and conditioning solid and liquid radioactive substances. Here, low-level and medium-level radioactive waste from the operation of the plant is prepared for proper disposal and stored in barrels. Along with the compacting system, a solidification and water treatment plant are available for this purpose. The wastewater processing unit filters radioactive water with low solid content so that, following testing in the laboratory, it can be reused in the plant. The changing area and access control to the reactor area as well as the intake and exhaust air system for the entire control area are also located in the treatment building.

Radioactive particles are removed from working materials, devices and smaller components in the decontamination plant, thereby ensuring that the radiation dose per person remains low during maintenance work and that material can be removed from the controlled area when necessary. A workshop is provided for carrying out maintenance or repair works on slightly radioactive parts. In the mock-up building, work on system components is prepared and practiced. As a result, time spent in the controlled area and hence exposure to radioactivity can be kept to a minimum during actual work.

One of the three feed water pumps, each one can supply 50 percent of the feed water.

A demineralizer provides deionized, ultrapure make-up water for the reactor and turbine system as well as their auxiliary facilities, including the clothes washer. The Reactor Water Clean-Up System (RWCU) constantly filters and demineralizes the ultrapure water in the primary circuit, thereby removing activated corrosion products and abrasive particles. These would otherwise be deposited on the fuel assemblies and – similar to a clogged up kettle – have a negative impact on the heat transfer to the water.

Such large amounts of laundry coming from the controlled area require heavy-duty washing machines.

The laundry service center also specializes in nuclear power plant applications. Under normal operation it processes up to 200 kg of protective clothing and shoes of employees working in the controlled area per day, whereas during the annual major overhaul it handles up to 2.7 t. Changing clothes ensures that no radioactive material is taken out of the Controlled Area. The wash water is cleaned, tested in the laboratory and only then authorized for release back into the Rhine. Contaminated residues are properly disposed of as low-level radioactive waste.



Photo: Ivo Stalder

Staff members cleaning radioactively contaminated objects always wear suitable protective clothing.

Zone overall repair is carried out on site.

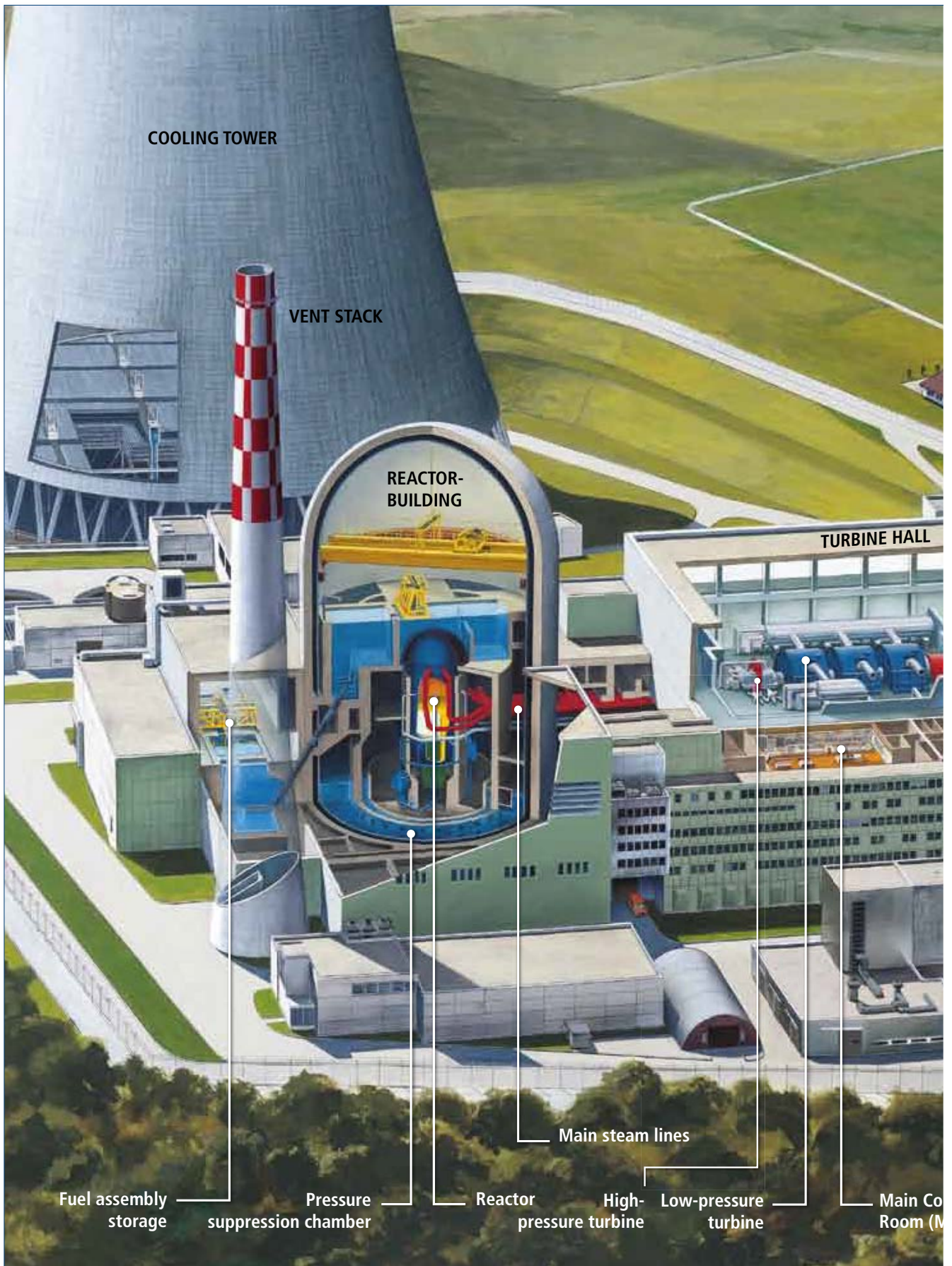

Photo: Palma Fiacco



Photo: Palma Fiacco

So much zone laundry requires heavy-duty washing machines.





Control
(CR)

Generator

Unit
transformer

Outdoor
switchyard

Conventional installations

■ Main heat cycle

Live steam comes out of the reactor at a temperature of 286 °C. Four main steam lines carry up to 2,000 kg of steam per second from the reactor to the high-pressure turbine. Two combined stop and flow control valves are located on each side of the high-pressure turbine.

The steam enters the high-pressure turbine at a pressure of 64, bar where it expands to 11.6 bar and cools down to 186 °C before flowing into the two moisture separator / reheaters. There it is dried and heated to a temperature of 263 °C. 8.5 percent of the main steam from the reactor is needed for this reheating step. The superheated steam then enters the three low-pressure turbines where it expands to between 0.1 and 0.2 bar and finally condenses in the condenser. Both the water separated in the water separator and the condensate from the reheaters are pumped into the feed water to take full advantage of their residual heat.

The main condenser sits at right angles to the turbine axis. Main cooling water flows through its four independent water chambers.

This design allows leaks to be localized, the affected condenser section isolated, and turbine operation to continue at reduced power.

The pressure of 0.1 to 0.2 bar inside the condenser is 0.8 to 0.9 bar below ambient pressure. This improves the thermal efficiency of the system. The vacuum in the condenser also prevents radioactivity in the steam of the primary circuit from passing into the cooling water in the event of a leak in the condenser.

Two main condensate pumps – a third is on standby – transport the condensate through the polishing plant. The condensate polishing plant removes contaminants such as chlorides and corrosion products to ensure the required high purity of the condensate. This is then pumped through two low-pressure preheaters into the surge tank. These three-stage low-pressure preheaters operate with heating steam from the low-pressure turbine. Condensate from the first two stages travels back to the condenser, and the condensate from the third stage is pumped into the surge tank.

- 1 Boiling water reactor
- 2 High-pressure turbine
- 3 Moisture separator
- 4 Intermediate reheater
- 5 Low-pressure turbine
- 6 Condenser
- 7 Turbine bypass lines
- 8 Main condensate pumps
- 9 Condensate polishing
- 10 Low-pressure preheater 1–3
- 11 Low-pressure preheater pump
- 12 Water separator pump
- 13 Surge tank
- 14 Feed water pump
- 15 High-pressure feed water heaters 5+6
- 16 High-pressure feed water heater pump
- 17 Feed water heater bypass line

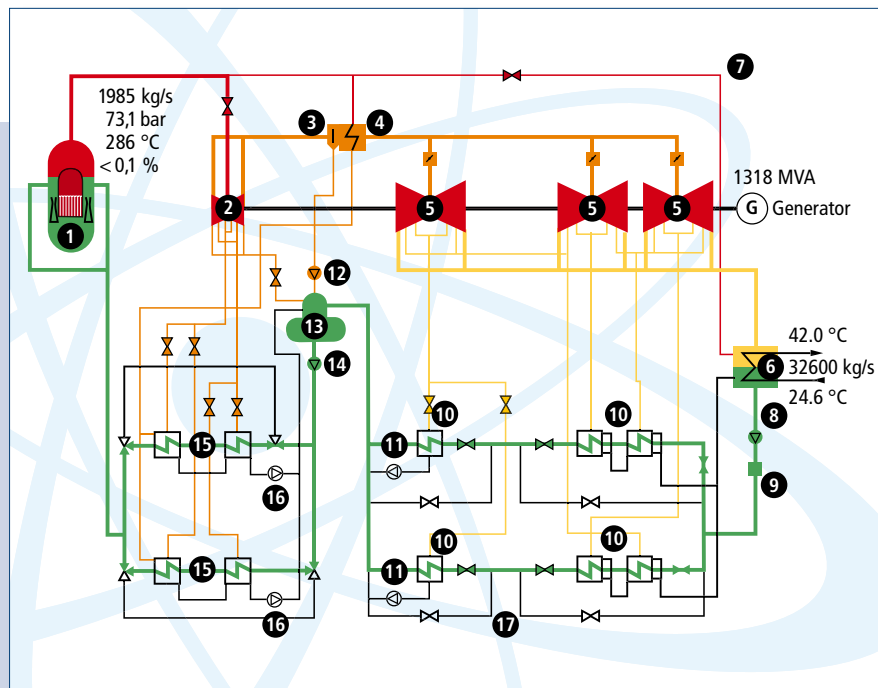

The heat flow diagram shows the live steam path via the condenser and back into the reactor. Steam is taken from the turbine to heat the feed water preheaters.

The surge tank acts as a mixer-preheater and is heated using the high-pressure exhaust steam as well as the residual heat in the condensate from the water separators and high-pressure feed water heaters. Feed water pumps transport the feed water through two high-pressure feed water heaters into the reactor pressure vessel. The steam for this two-stage preheater comes from the high-pressure turbine; the hot condensate passes to the surge tank. In normal operation, the two feed pumps are running at 50 % capacity and a third is on standby.

The noncondensable gases which form in the reactor during operation and collect in the condenser are transported to the waste gas purification plant by means of steam jet ejectors.

■ Turbine-generator set

The turbine-generator set consists of one high-pressure and three low-pressure turbines made by the French company Alstom. The high-pressure turbine generates 40 % of the total output of Leibstadt Nuclear Power Plant, whereas the three low-pressure turbines between them supply the remaining 60 % of the overall output.

The turbine-generator set is designed with double-inlets. The high-pressure section has nine stages and the three low-pressure turbines six stages each. A thrust bearing is used between the high-pressure and the first low-pressure turbine to fix the 33 m long turbine shaft, in the horizontal direction. Between the housings of the low-pressure rotors is a single radial bearing on which the shaft runs. In total, seven radial bearings support the shaft, which has a total length of 52 m, including the generator rotor.

The maximum thermal expansion of the turbine rotor is 38 mm. Inactive gland sealing steam from separate steam converters provides the seal between the rotors and the turbine housing. This gland sealing steam system prevents radioactive steam from escaping into the turbine building via the rotor seals or valve spindles.

The turbine must meet very strict precision and quality requirements.

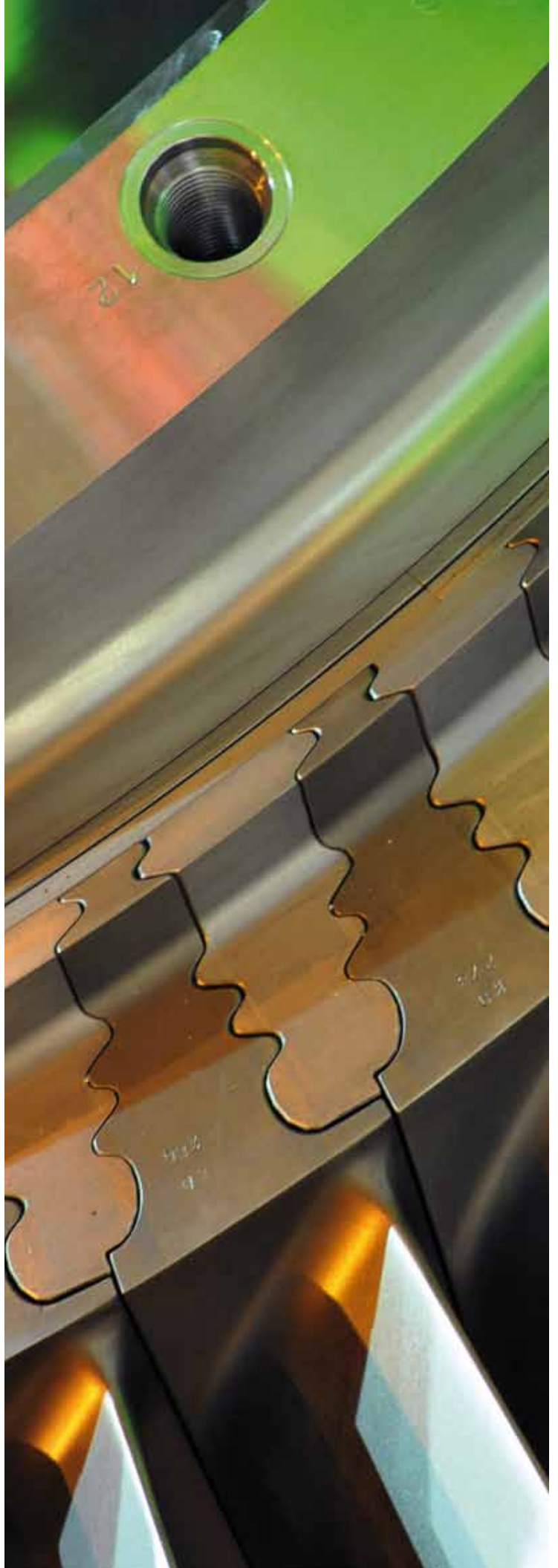

At various points of the turbine housing, steam is drawn off for the purpose of heating the feed water preheaters. A bypass system makes it possible to temporarily direct all the steam from the reactor straight into the condenser.

■ Generator

The two-pole generator is coupled directly to the low-pressure section of the turbine. The mechanical output of the plant's turbines is gigantic (1.7 million HP). This mechanical output is transferred by the rotation of the turbine shaft to the generator shaft, which rotates at a rate of 50 revolutions per second. With a height of

four meters and a length of ten meters, the generator housing encases an eight meter long stator that weighs 520 t. The rotor weighs an additional 95 t. At a terminal voltage of 27 kV, the generator has a rated apparent power of 1318 MVA.

The generator must be cooled during operation. As is customary for large generators, mixed cooling is used: The rotor winding, air gap and stator core are cooled with hydrogen gas, while the stator winding and down conductor are cooled with water. A static system utilizing thyristors is used to excite and control the generator. The exciter power is taken directly from the generator bus ducts via a matching transformer. Three air-cooled power lines transport the power from the generator to the unit transformer.

Photo: Palma Fiacco

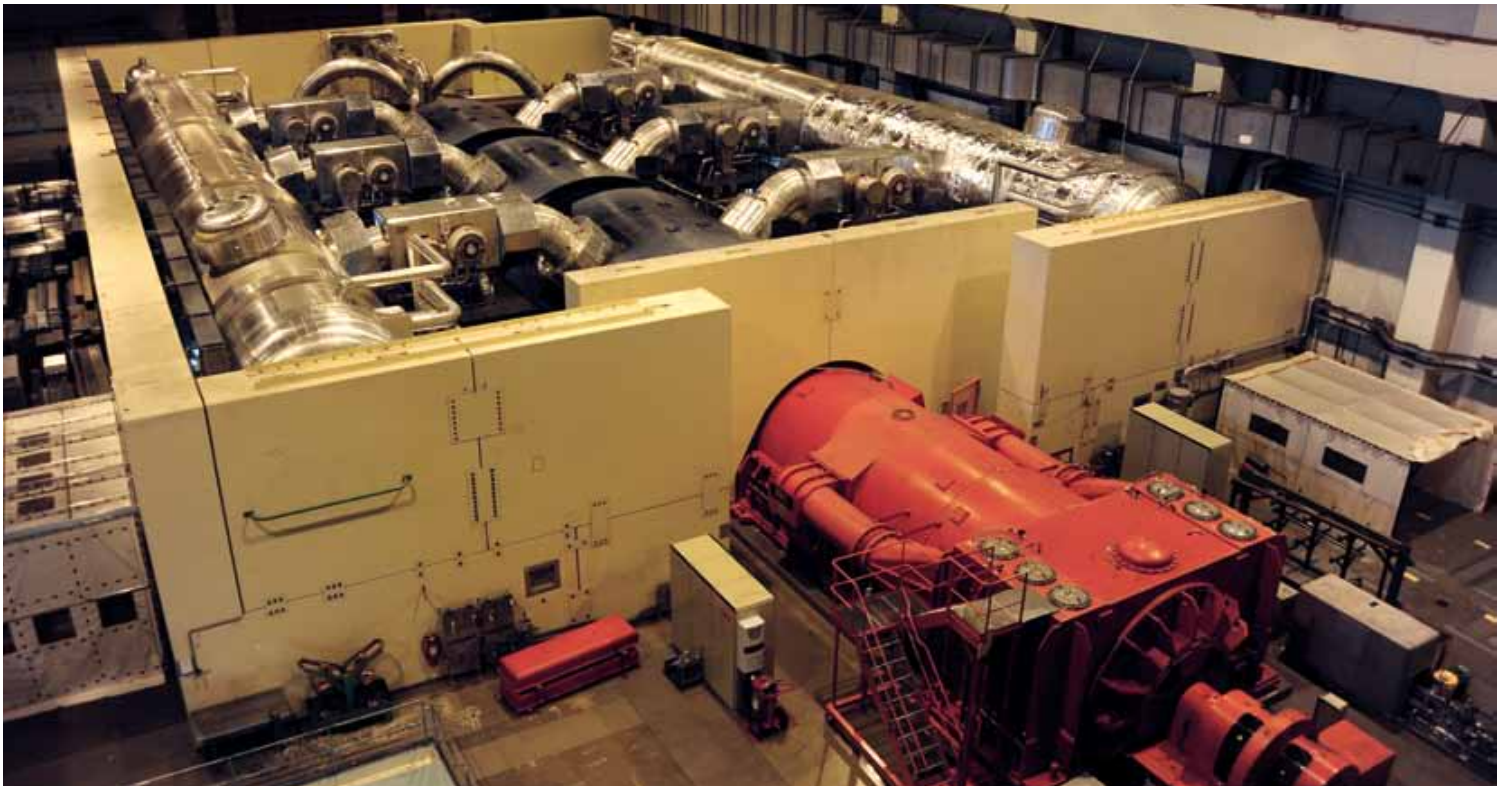

The high-pressure and low-pressure turbines are mounted along the same axis as the generator; the water separator/reheater can be seen to the left and right.



Photo: Archiv KKL

When the rotor is dismantled, a look into the generator shows the winding head with the connections for the water cooling system.



Photo: Archiv KKL

After servicing, the blade carrier casing is mounted back onto the low-pressure turbine.



Photo: Peter Graf

The removed rotor of a low-pressure turbine shows clear signs of corrosion from use.

Cooling systems

■ Main cooling system

The 144 meter high cooling tower is the most conspicuous feature of the secondary water circuit, which serves the purpose of cooling the condenser. Four main cooling water pumps (each with a 25 percent capacity rating) draw the cooling water (33 m³/s) out of the cooling tower basin. They pump it through underground pipes to the condenser in the turbine building, where it is heated to over 45 °C. From there, the water flows back into the cooling tower. An elaborate ducting system distributes the returned cooling water to the drip plates where it drains off. The strong rising airflow cools the dripping water to about 30 °C. In addition, it lifts part of the water and forms a cloud of pure water vapor above the tower. The shape and size of this cloud depends on local weather conditions. Such a natural draft cooling tower can dispense with fans and other technical devices. The thermal capacity is approximately 2350 MW.

Evaporative losses in the cooling tower average 720 kg/s. This water needs to be replaced. For this purpose, an average of 915 kg/s is taken out of the Rhine. The Rhine water must be treated to ensure that, despite concentration, as cooling water it does not contaminate the condenser through evaporation. Excess water (about 200 kg/s) is released back into the Rhine in compliance with the water protection regulations. When the Rhine water is treated, suspended matter is first separated by adding flocculant, after which the water is slowly decarbonized by adding lime slurry. After separation and drying, about 30 t per day of lime sludge is currently used by local farmers to improve the soil chemistry of fields in the southern part of Germany's Black Forest area.

The cooling water drips off into the collection basin forming a glistening curtain.

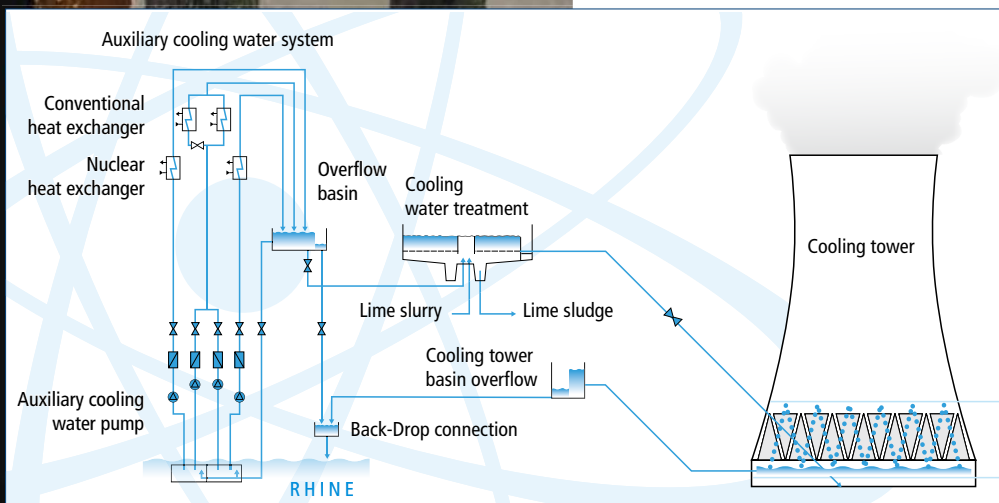

Rhine water is used to cool the intermediate cooling circuits of the plant and to replace the evaporated water in the cooling tower. This amounts to a maximum of 4 m³ per second. In comparison: the Rhine's water flow totals about 1000 m³ of water per second.

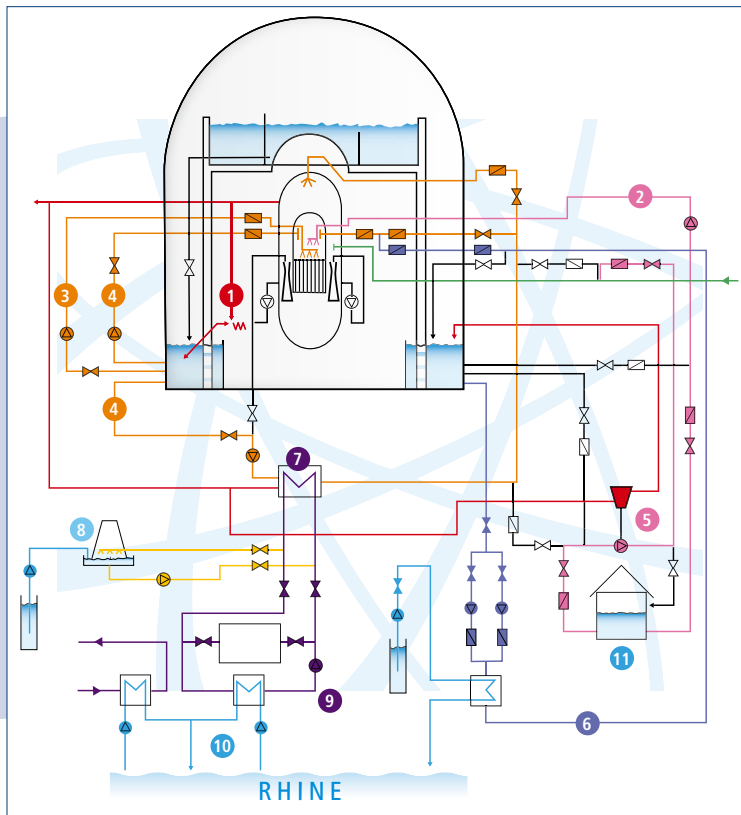

- 1 Automatic Depressurization System (ADS)
- 2 High-Pressure Core Spray system (HPCS)
- 3 Low-Pressure Core Spray system (LPCS)
- 4 Low-Pressure Coolant Injection system (LPCI)
- 5 Reactor Core Isolation Cooling system (RCIC)
- 6 Special Emergency Heat Removal system (SEHR)
- 7 Residual Heat Removal (RHR)
- 8 Essential Service Water system (ESW)
- 9 Nuclear Island Closed Cooling Water (NICCW)
- 10 Auxiliary Cooling Water (ACW)
- 11 Cold Condensate Tank (CCT)

Multiple redundant, i.e. additional systems ensure that the reactor core can be cooled even in emergency situations.

■ Auxiliary cooling water system

Additional cooling water for the power plant is provided by the auxiliary cooling water system. It cools the intermediate cooler in the reactor auxiliary building and in the turbine building via two separate pipelines. The heat dissipated by these closed intermediate loops comes mainly from room cooling, generator cooling, various pumps, fuel assembly pool, and when the reactor is shut down, from the Residual Heat Removal system (RHR). The thermal capacity of the auxiliary cooling water system amounts to 50 MW. It uses approximately 2,500 kg/s of Rhine water.

A portion of the heated return is conducted from the overflow basin as make-up water to the cooling tower water treatment plant. The rest flows back into the Rhine via the back-drop connection. The water flowing back into the river must not exceed 30 °C.

■ Emergency cooling systems

The Essential Service Water System (ESW) with its own three emergency cooling towers is available if it is not possible to use Rhine water, for example, because there is no power for the pumps. In emergency situations, this system takes over the function of the auxiliary cooling system and dissipates the residual heat from the reactor

via the RHR system. The water-supply lines to the cooling units as well as the electric control lines are suitably placed and well protected. The water is taken from the groundwater and drawn up with pumps; the power is safely provided by five independent fast-starting Emergency Diesel Generators (EDGs).

In case of coolant loss in the primary circuit, several independent systems are on standby and automatically start up to supply the reactor core with water and cooling: the High-Pressure Core Spray system (HPCS), the Low-Pressure Core Spray system (LPCS) and the triple-redundant Low-Pressure Coolant Injection system (LPCI). All Emergency Core Cooling Systems (ECCS) have independent, earthquake-proof and flood-proof power supplies, emergency cooling towers and cooling through groundwater.

Another important emergency cooling system is SEHR (Special Emergency Heat Removal). It consists of two redundant system chains and starts up automatically when required. The SEHR system ensures that the reactor can be safely cooled for hours without the need for intervention by staff. The SEHR system is constructed below ground and is thus protected against external events.

The cooling water for virtually all emergency cooling systems is taken from the water chamber of the Pressure Suppression Pool.



Photo: Palma Fiacco

Electrical installations

Hundreds of instruments constantly monitor plant conditions.

■ Main transformer

The power produced by the generator is transferred to the unit transformer made by the Dutch company SMIT via the generator circuit breaker. Each of the three single-phase transformers weigh about 320 t. They have a power rating of 500 MVA and transform the voltage from 27 to 380 kV. A fourth transformer is kept as a standby. The transformers feed the power to the outdoor switchyard. An overhead power line from each transformer connects the Leibstadt Nuclear Power Plant to the switchyard of the nearby European network control station in Laufenburg, the heart of the Swiss power network, and, via the switchyard in Beznau, to the 380 kV ultra-high-voltage grid.

■ House load

The Leibstadt Nuclear Power Plant needs roughly 55 MW of its electric power to cover its own power needs – 35 MW alone for the pumps in the feed water, condensate and cooling water systems. This on-site power requirement is covered by two independent systems (divisions). Each is supplied by its own three-phase transformer (27 kV to 10 kV).

When the generator is at a standstill, the plant's on-site power requirements are covered by external power from the 380 kV grid. When the 380 kV substation is switched off for maintenance work or grid malfunctions occur, two independent 50 kV lines with their own transformers guarantee that the plant's on-site needs are

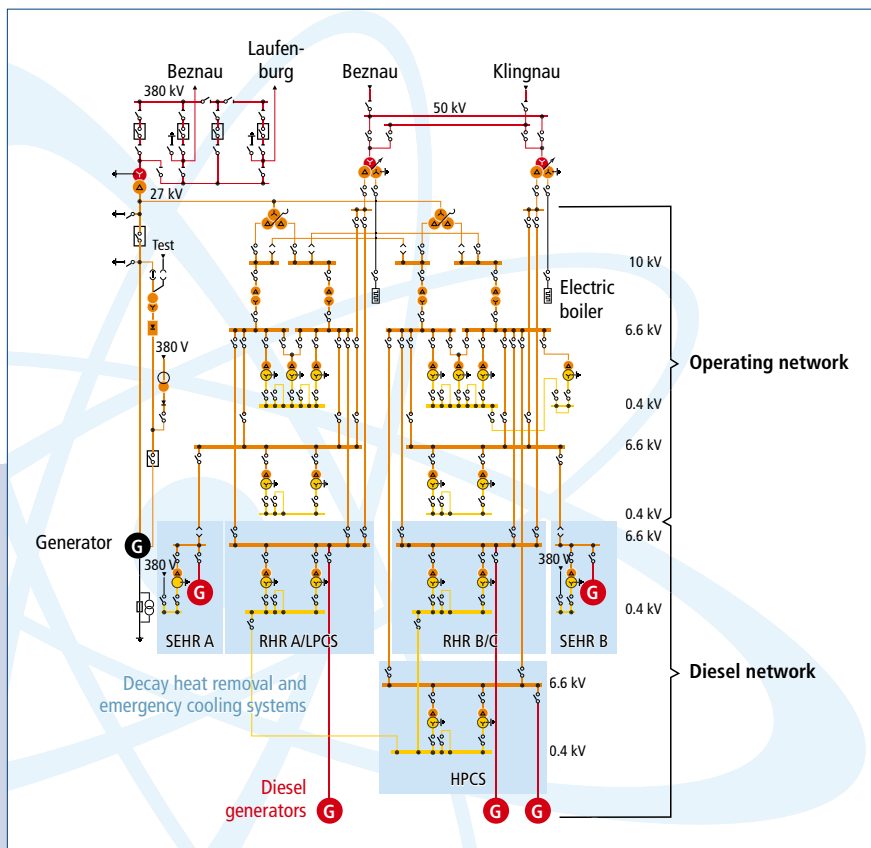

The diagram shows the on-site power requirements of Leibstadt Nuclear Power Plant and its connection to the high-voltage network (380 kV).

covered. One of these lines leads directly to the substation of the Klingnau Hydroelectric Plant, while the other one is connected to the existing 50 kV Beznau-Klingnau power line. Thanks to these 50 kV supplies, the turbine group can be switched off with no damage even in case of failure of the 380 kV grid.

■ Emergency power supply

In case of an external power supply failure, independent Emergency Diesel Generators guarantee that the plant's power needs are met. The three large turbocharged V20 diesel generators made by the German manufacturer MTU permit safe shutdown and subsequent cooling of the reactor. Each has a constant power output of 4595 kW (6250 HP). In addition, two smaller emergency V12 diesel generators are available in the bunkered SEHR system, each with an output of 2200 kW (3000 HP).

All Emergency Diesel Generators are constantly preheated and thus only need a few seconds from start to full capacity. They are tested monthly to ensure that they are fully functional.

Important DC loads such as control electronics, measuring instruments, special pump motors, valves, and emergency lighting must continue to be supplied without interruption even in case of a power failure. For this reason, they are connected to five independent 220 V battery systems. The control systems obtain their energy from seven separate 24 V battery systems.

Photo: Ruth Schmid



Three transformers form the unit transformer; the fourth one on the left is kept as a standby transformer.

■ Remote Shut-Down Areas

All the systems needed to operate the power station can be controlled automatically or manually from the Main Control Room. Should the Main Control Room become unavailable, Remote Shut-Down Areas in the auxiliary building can be used. The Special Emergency Heat Removal system (SEHR) has its own control rooms and runs completely automatically and autonomously.

Photo: Palma Fiacco



The 20-cylinder engine of an Emergency Diesel Generator.

The fuel used at Leibstadt Nuclear Power Plant



Photo: US NRC

Uranium is sold as a yellow or black powder (U_3O_8).

■ Fuel procurement

The fuel used at Leibstadt Nuclear Power Plant is purchased by Axpo AG, which also manages KKL AG. The uranium used currently comes from Russia, whereas the fuel assemblies are manufactured in Western Europe. Contracts secure the fuel supply for years in advance. Leibstadt Nuclear Power Plant imposes its own tough nuclear safety demands on suppliers and subcontractors. The plant thereby ensures that, even when it comes to fuel procurement, all partners are subject to proper regulatory supervision. In addition, Leibstadt Nuclear Power Plant requires producers to adopt an up-to-date environmental policy (ISO 14001 or equivalent), that they comply with international occupational safety standards (OHSAS 18001 or equivalent), and that they are committed to international human rights norms (UN, ILO).

■ Fuel consumption

In order to be able to use uranium in the reactor of Leibstadt Nuclear Power Plant, the proportion of U-235 must be raised from 0.7% to an average of 4.25%. This enriched uranium is used in the fuel assemblies in the form of uranium dioxide (UO_2). Every year, Leibstadt Nuclear Power Plant uses about 128 fuel assemblies of which each one contains roughly 205 kg of enriched uranium dioxide. This annual consumption amounting to just over 26 t of uranium dioxide is obtained from approxi-

Three isotopes of the heavy metal uranium exist in nature. They differ in the number of neutrons in the nucleus: uranium-234 (92 protons + 142 neutrons = 234 nuclear particles), uranium-235 (143 neutrons). Natural uranium only contains traces of uranium-234 and roughly 0.7% uranium 235. The largest proportion consists of uranium 238 (about 99.3%). Only uranium 235 is easily fissionable..

mately 190 t of natural uranium and corresponds to 980 kg of the fissionable U-235. Uranium is very heavy and energy-dense. The 26 t annual requirement of Leibstadt Nuclear Power Plant has a volume of only about 2.5 m³ and would thus easily fit into the cargo space of a small delivery truck. From this small amount of fuel, the power plant generates electricity for more than one million people every year!

■ Reprocessing

Until the ten-year moratorium came into force in mid-2006, Leibstadt Nuclear Power Plant sent part of the spent fuel assemblies, which still contains usable plutonium and about 0.6% of unused U-235, to a reprocessing plant. In this recycling process, reusable materials are separated from the waste. The uranium obtained this way can be reused in ERU fuel assemblies (Enriched Reprocessed Uranium) and the plutonium in Mixed Oxide fuel assemblies (MOX). All waste is treated and transported back to Leibstadt Nuclear Power Plant or to the interim storage facility (ZWILAG) co-financed by the Leibstadt Nuclear Power Plant. For this purpose, the highly radioactive waste components such as fission products (short-lived radioactive by-products of the fission process) and actinides (long-lived radioactive isotopes which are created through neutron capture and subsequent decay) are glazed in the reprocessing plant before being poured into steel barrels. Both volume and long-term radiotoxicity of the highly radioactive waste products are significantly reduced through reprocessing.

So far, Leibstadt Nuclear Power Plant has not used any recyclable fuel obtained from reprocessing its own fuel assemblies. The plutonium from spent Leibstadt fuel has already been used as MOX at Beznau Nuclear Power Station. The reprocessed uranium can also be used there or at Leibstadt.

Waste

■ High-level radioactive waste

The spent fuel assemblies are highly radioactive. They generate significant amounts of heat and must be cooled down for several years in the Spent Fuel Pool before being transported to the interim storage facility.

Today, Leibstadt Nuclear Power Plant must dispose of 12 m³ of spent fuel assemblies per year. Compared to the amount of electricity produced, this amounts to one third less than was generated when the plant first started operating. The reason for this reduction is that the efficiency of the nuclear fuel, and hence of the plant as a whole, has been significantly increased through technical developments. The useful life of each fuel assembly was able to be increased by one third and, even though the reactor output rose by 15 %, the consumption of fuel assemblies (uranium, zirconium) is down. This means that more power can be generated from less uranium.

■ Low-level and medium-level radioactive waste

Waste from the power plant consists of low-level and medium-level radioactive waste. This includes cleaning cloths, foils, zone clothing, cover sheets, packaging and



Photo: Ivo Stalder

The yellow barrels are for low and medium-level radioactive waste.

other maintenance materials. Part of this waste is compressed in the plant and put into 200 liter barrels. Having been transported to the interim storage facility in Würenlingen, this waste is melted down in the plasma furnace and filled into ingot molds. The slag in the ingot molds is cemented into barrels. Other process-related waste such as resins, concentrates, sludge, and exhaust air filters are embedded in concrete inside barrels directly at the Leibstadt Nuclear Power Plant. Low-level and medium-level radioactive waste generates only insignificant amounts of heat or no heat at all.

Due to plant optimizations, employee training and minimization concepts, these low-level and medium-level waste products have also been considerably reduced over the years. Thus, the plant now produces at total of about 40 m³ of low-level to medium-level waste prepared for final disposal per year – roughly 30 % less than 20 years ago.

All these improvements help meet the demand for sustainable development: they save natural resources and help to reduce radioactive waste and the plant's impact on the environment to an absolute minimum.

■ Transportation and storage containers

In order to transport the spent fuel assemblies to the interim storage facility, they must be put into special containers which are also used for storage. Each container holds up to 70 fuel assemblies, is just over six meters long and about three meters in diameter. These complex, extremely thick-walled and solid containers meet the IAEA standard, offer optimal protection against radiation and can withstand falls from great heights, fire and even the crash of a military jet. When transporting the material to the interim storage facility, staff members are exposed to less radiation than pilots during a transatlantic flight.

Enclosed in extremely solid containers, spent fuel assemblies are stored in the interim storage facility until their final disposal in a deep geological repository.



Photo: Ivo Stalder

Safety of the Leibstadt Nuclear Power Plant

Operation of a nuclear power plant requires compliance with the highest standards of reactor safety and radiation protection. The goal of nuclear safety technology is to ensure that equipment and systems meet a standard of reliability and availability which satisfy the conditions for safe operation. Permanent monitoring and preventive maintenance of the plant are indispensable. The foremost consideration is the protection of people living in the plant's vicinity and of workers at the plant from harmful radioactivity. The high safety standard of Leibstadt Nuclear Power Plant is based on passive, i.e. mostly structural, and active measures in the form of multiple technological barriers which are complemented by a constantly practiced safety culture.

■ Protection of people, the environment and the plant

The environment is protected from radioactivity inside the nuclear steam supply system of Leibstadt Nuclear Power Plant through several structural measures based on an onion layer model. The fuel in the form of Uranium pellets is sintered, i.e. baked into hard ceramic grids. As a result, solid substances cannot escape. The pellets in turn are welded into gas-tight fuel rod cladding tubes,

which prevent gaseous fission products from escaping. The fuel assemblies are enclosed in the Reactor Pressure Vessel, a 15 cm thick steel container which shields most of the radiation. The Reactor Pressure Vessel is in turn encased by the Drywell, a 1.5 m thick reinforced concrete wall. The Drywell itself is completely surrounded by the Containment structure, a 3.8 cm thick steel jacket. This steel shell is protected by the exterior wall of the reactor building, a strongly reinforced concrete wall with a thickness of 1.2 m.

The Containment structure offers optimal protection against the release of fission products and radioactively contaminated material, both during normal operation and in the very unlikely event of a serious accident. A vacuum exists in the space between the Reactor Building and the steel Containment structure. This negative pressure enables reliable monitoring and prevents airborne radioactivity from escaping into the air. When required, automatically closing isolation valves ensure complete separation of the containment structure from the rest of the plant. An additional Filtered Containment Venting system is installed for the very improbable case of an excessive pressure rise in the Containment structure.

Leibstadt Nuclear Power Plant is solidly built in order to safeguard it against external events. For example, the wall of the reactor building is made from special con-

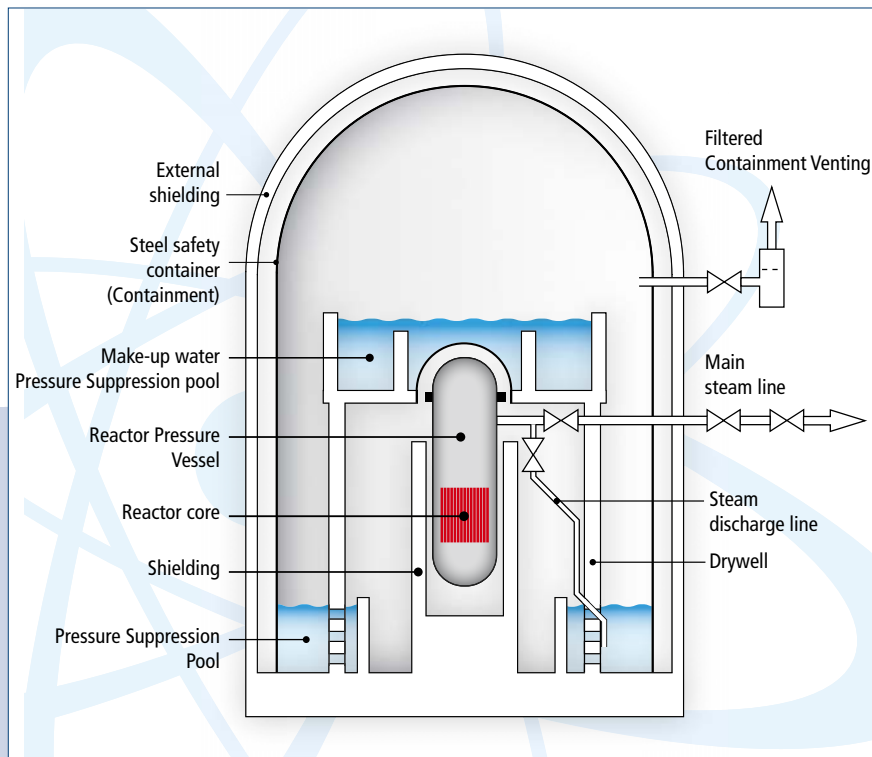

The cross-section of the Reactor Building shows the very solid structural barrier system. It protects the reactor from external influences while at the same time shielding the environment from radiation.



Photo: Ruth Schmid

Clear danger signs and instructions are fundamental to ensuring employee safety.

crete which contains twice as much cement as is used when a tunnel is built through the Alps. The calculations for the building structures are based on the safety criteria commonly used for nuclear power plants. Situations determined by the physical location such as earthquakes, flooding or plane crashes were taken into account when the plant was designed. If a large modern commercial airplane was to crash into the Reactor Building, it would only cause slight damage to its outer shell. It would not affect the Containment structure or its protective function.

■ A permanently practiced culture of safety

Safety is continuously improved through optimizing the interplay between man and machine. The nuclear power industry engages in a constant exchange of information to ensure that lessons are learnt from mistakes made elsewhere. In addition, safety means that the plant is constantly modernized and updated to reflect the latest technological developments. Leibstadt Nuclear Power Plant is a modern power station run by well-trained and qualified personnel. For example, it is compulsory for operators to undergo training on the simulator in different operational situations and accident scenarios several times a year. In addition, similar to airline pilots, they must renew their license every two years. A technical quality management system supports working processes, and the plant's own safety assurance program,

*With its **nuclear safety charter**, Leibstadt Nuclear Power Plant commits itself to take measures to continuously improve the safety and operation of the plant, as well as to ensure protection from radiation. The key aspect of the plant's safety policy is compliance with all legal requirements. The charter provides the basis for carrying out their daily tasks and responsibilities for all Leibstadt employees.*

as well as periodic safety checks by the authorities, promote continuous safety improvements.

■ Regulatory control

Apart from structural measures and a high level of safety culture, a body of rules and regulations ensures that the public, the plant's employees, and the environment are protected from radioactivity. After all, the Leibstadt Nuclear Power Plant does emit radiation. However, the quantity of the radiation released is far below the statutory limits, typically reaching a maximum of 10 % of the limits laid down in the regulations. These substances account for less than 1 % of the average level of background radiation. This means that no elevated radiation can be measured in Leibstadt. Thanks to detailed planning of all operations and extensive radiation protection measures, even the average radiation dose received per year and employee is only 0.5 mSv, while the highest single dose is usually about 50 % of the legal limit of 20 mSv. To put this into perspective, natural background radiation in the Black Forest (Menzenschwand spa resort) amounts to 20 mSv per person per year.

An entire network of measuring stations in the immediate and surrounding areas, including the German side of the border, constantly monitors the plant's air, water and soil emissions as well as direct radiation. These measured values are checked by Leibstadt Nuclear Power Plant itself, via the MADUK network of the Swiss Federal Nuclear Safety Inspectorate ENSI (updated measured values available on SF DRS teletext) and by the NADAM probes of the National Emergency Operations Centre (NEOC) (latest measurement data at www.naz.ch). The Swiss Federal Institute of Aquatic Science and Technology (Eawag) and the Section for Radiation Monitoring (SUeR) also operate their own measuring stations.

The power plant is protected against unauthorized access.



Photo: Ruth Schmid



Photo: Karin Gfeller

The natural surroundings of Leibstadt Nuclear Power Plant even appeal to peregrine falcons, which have used the plant's cooling tower to nest in for many years.

Environmental aspects

■ Greenhouse gases

Leibstadt Nuclear Power Plant is virtually free of greenhouse gases. Since no fossil fuel is burnt, no CO₂ is produced during electricity generation – in contrast to all other thermal power stations. If all upstream and downstream processes and energy flows from Uranium mining to waste disposal are included in the calculation, the greenhouse gas emission is still excellent: for each kilowatt hour of electricity generated, only eight grams of CO₂ equivalents are produced. In comparison, brown coal power stations of the type still used in Germany produce 1231 g of CO₂ equivalents/kWh. Gas power plants emit 644 g of CO₂ equivalents/kWh, and even a gas-fired combined cycle power plant still releases 426 g of CO₂/kWh.

Switzerland's current power generation mixture is practically unbeatable in terms of its greenhouse gas emissions: thanks to 40% nuclear energy and 55% equally climate-friendly hydroelectric power, electricity generation only accounts for 2.3% of Switzerland's total greenhouse gas emissions. By comparison, the global average is about 40%.

■ Emissions into the air and water

The Leibstadt Nuclear Power Plant hardly releases any emissions into the atmosphere. All waste air from the plant is filtered and radioactive particles (aerosols) are prevented from leaking out. Radioactive gases are treated in the Off-Gas Treatment system where they remain for about 50 days, i.e. until their radioactivity has for the most part decayed. Only a small amount of inert gases

(krypton and xenon) are released into the atmosphere together with the filtered exhaust air from the plant via a vent stack.

Radioactive waste water is also produced by Leibstadt Nuclear Power Plant. This is waste water from device and

All radioactive emissions into the air and water amount to a fraction of the already low maximum permissible values permitted by the authorities.

floor drainage, the plant's own laundry facility and the laboratories. All water from the controlled area is evaporated or cleaned by means of centrifuges. What remains in the form of solid substances is solidified and stored in barrels. The treated water is tested, registered and then drained into the Rhine. This means that only low quantities of radioactivity are released into the Rhine.

A unique construction

In order to ensure that the temperature and ecological balance of the Rhine is not affected in any way, Leibstadt Nuclear Power Plant was built with a natural draft cooling tower instead of direct water cooling. Similarly, neither the heat nor the vapor from the cooling tower impact the local climate. However, depending on the weather conditions, the size of the cooling tower vapor plume casts a considerable shadow.

Backside:
Electricity is transported from
the generator to the unit transformer
via air-cooled lines.



Photo: Palma Fiacco

Kernkraftwerk Leibstadt AG, Information Center, 5325 Leibstadt, Switzerland